

Maria Marjunardóttir Dahl

# Genomsekventering av Koronavirus í Føroyum

# Genomsekventering

Royndir við genomsekventering av laksa-virusum

- ILAV
- PMCV
- PRV

Nytta av genomsekventering

- Smittuketur/vegir
- Mutatióinir, ið kunnu ávirka virulence
- Mutatióinir, ið kunnu ávirka vaksinu

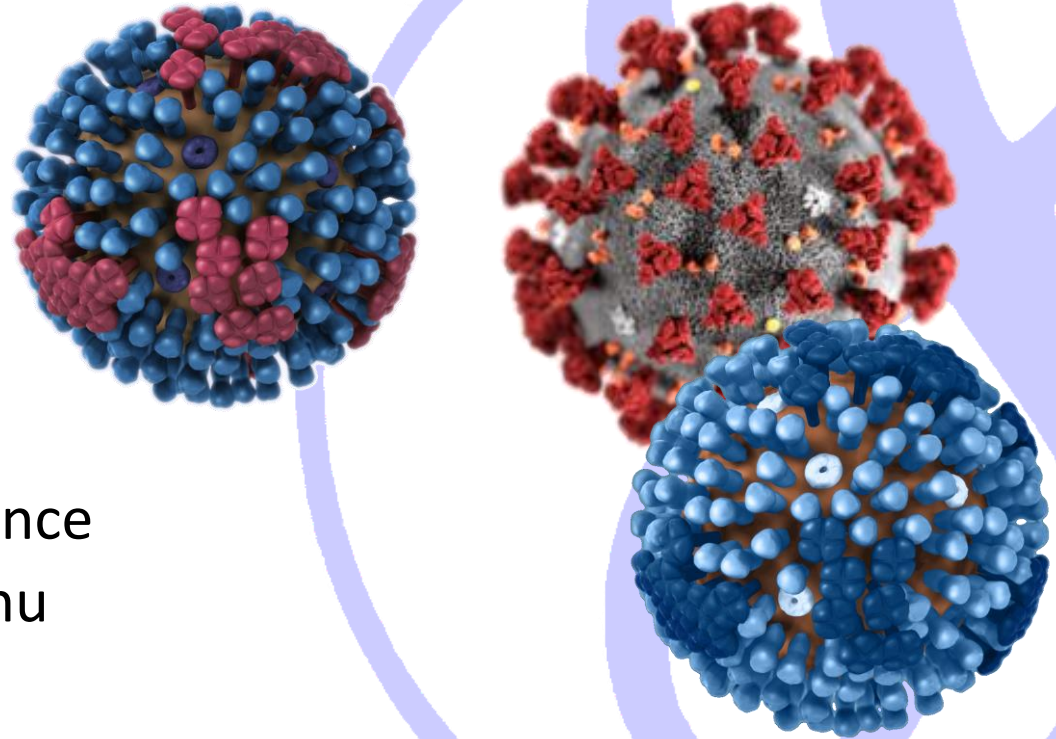

# SARS-CoV-2

- RNA virus
- 30.000 nukleotidur langur arvastrongur
- Fyrsta genomið úr Wuhan/Kína
- GISAID
  - altjóða granskingarbólkur, ið umsitur genom-databasan

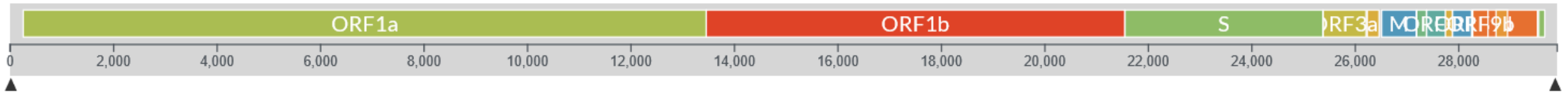

# Mannagongd

- Poting frá einum persóni



# Mannagongd

- Poting frá einum persóni
- Uppreinsað RNA frá prøvanum
  - Arvamaterialið hjá bæði persóni og virusi

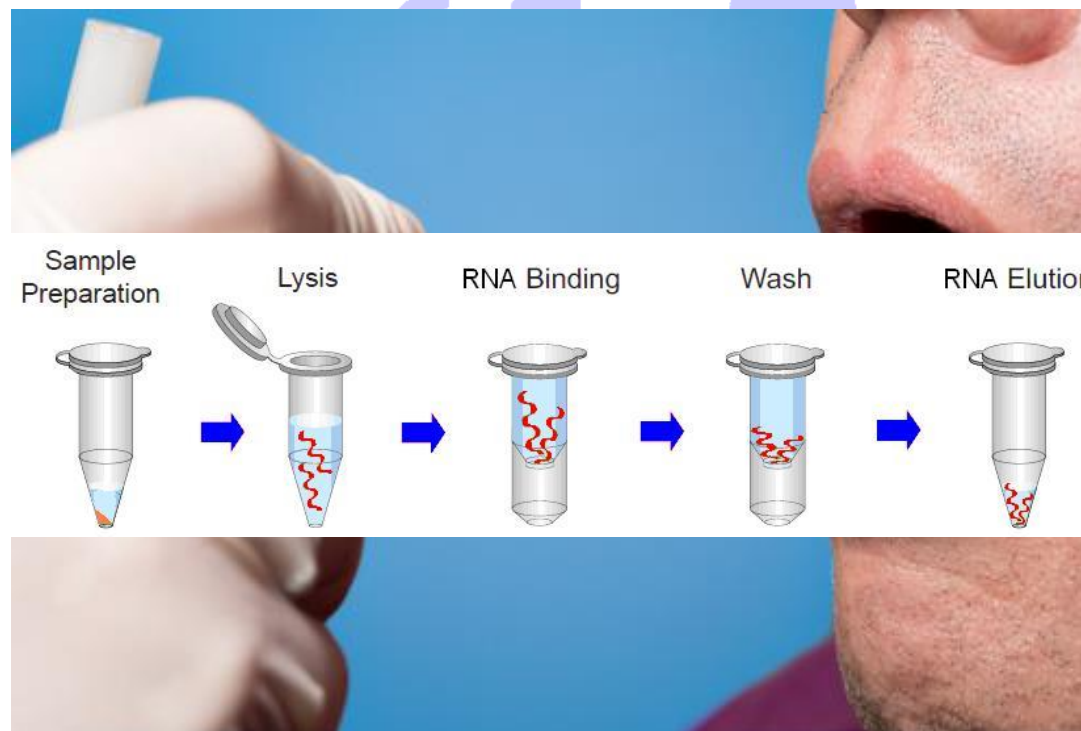

# Mannagongd

- Poting frá einum persóni
- Uppreinsað RNA frá prøvanum
  - Arvamaterialið hjá bæði persóni og virusi
- SARS-CoV2 positivur prøvi

Amplification Plot

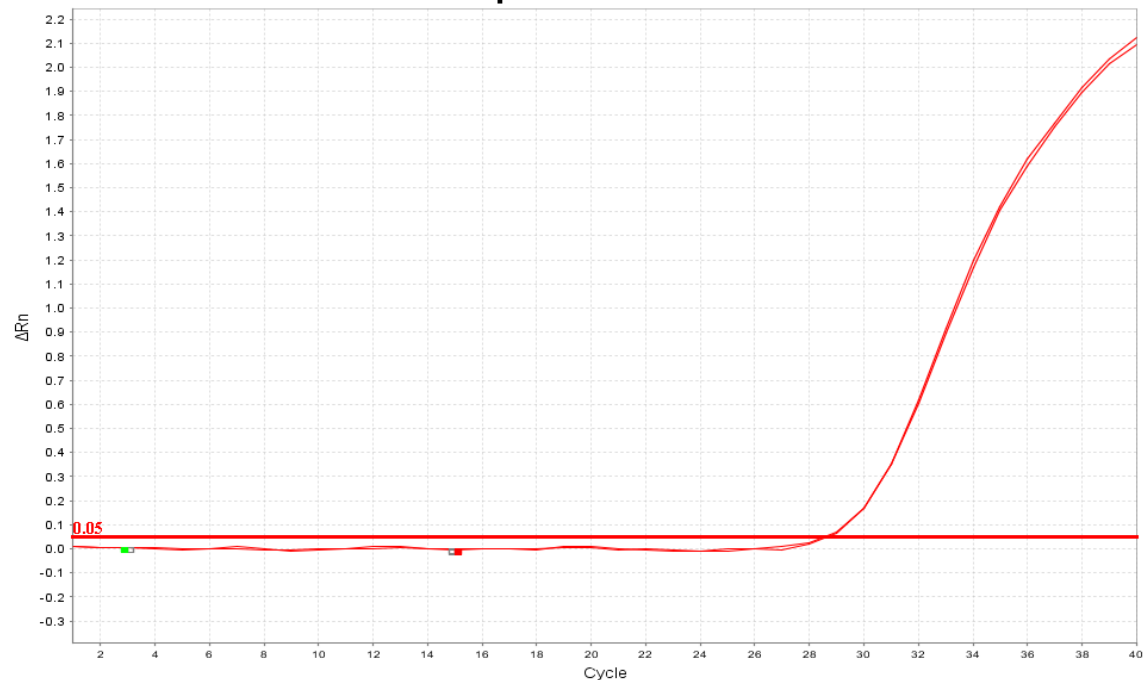

# Mannagongd

- Poting frá einum persóni
- Uppreinsað RNA frá prøvanum
  - Arvamaterialið hjá bæði persóni og virusi
- SARS-CoV2 positivur prøvi
- RNA til cDNA

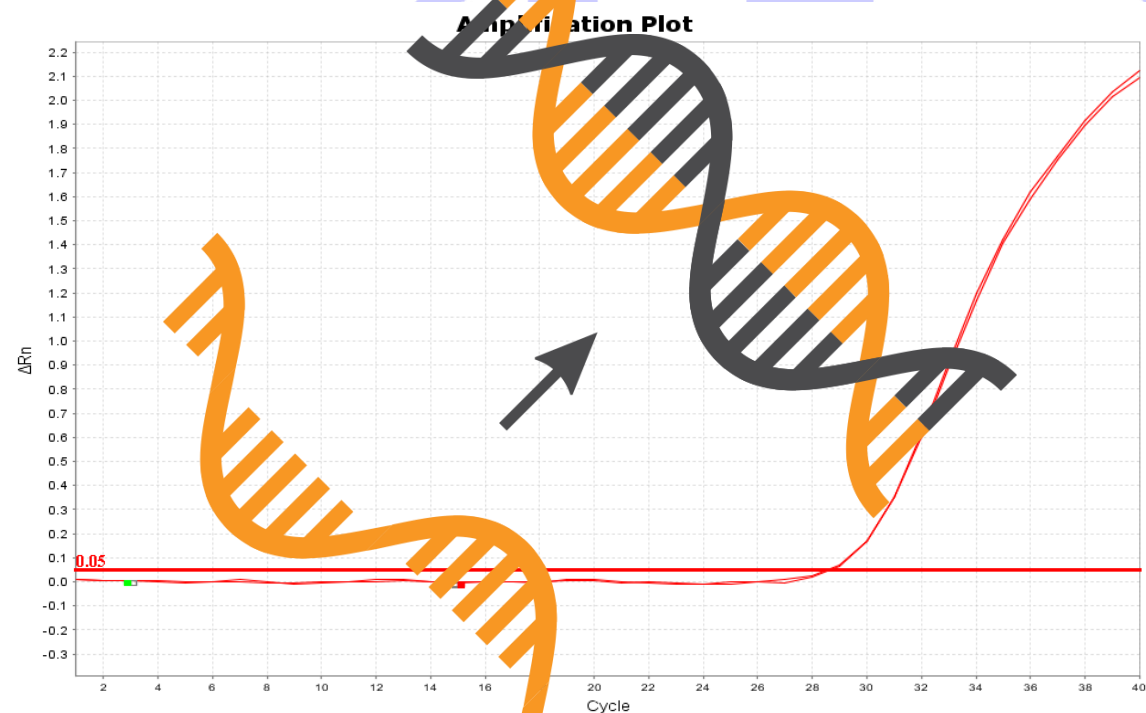

# Mannagongd

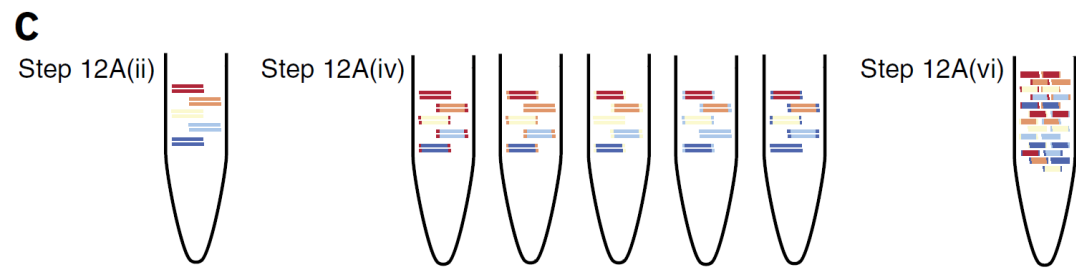
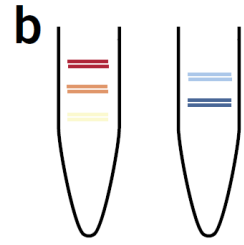
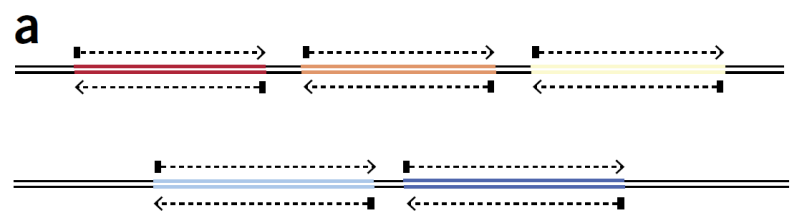
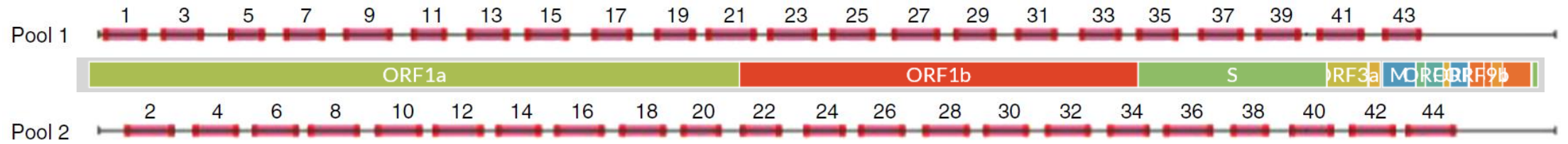



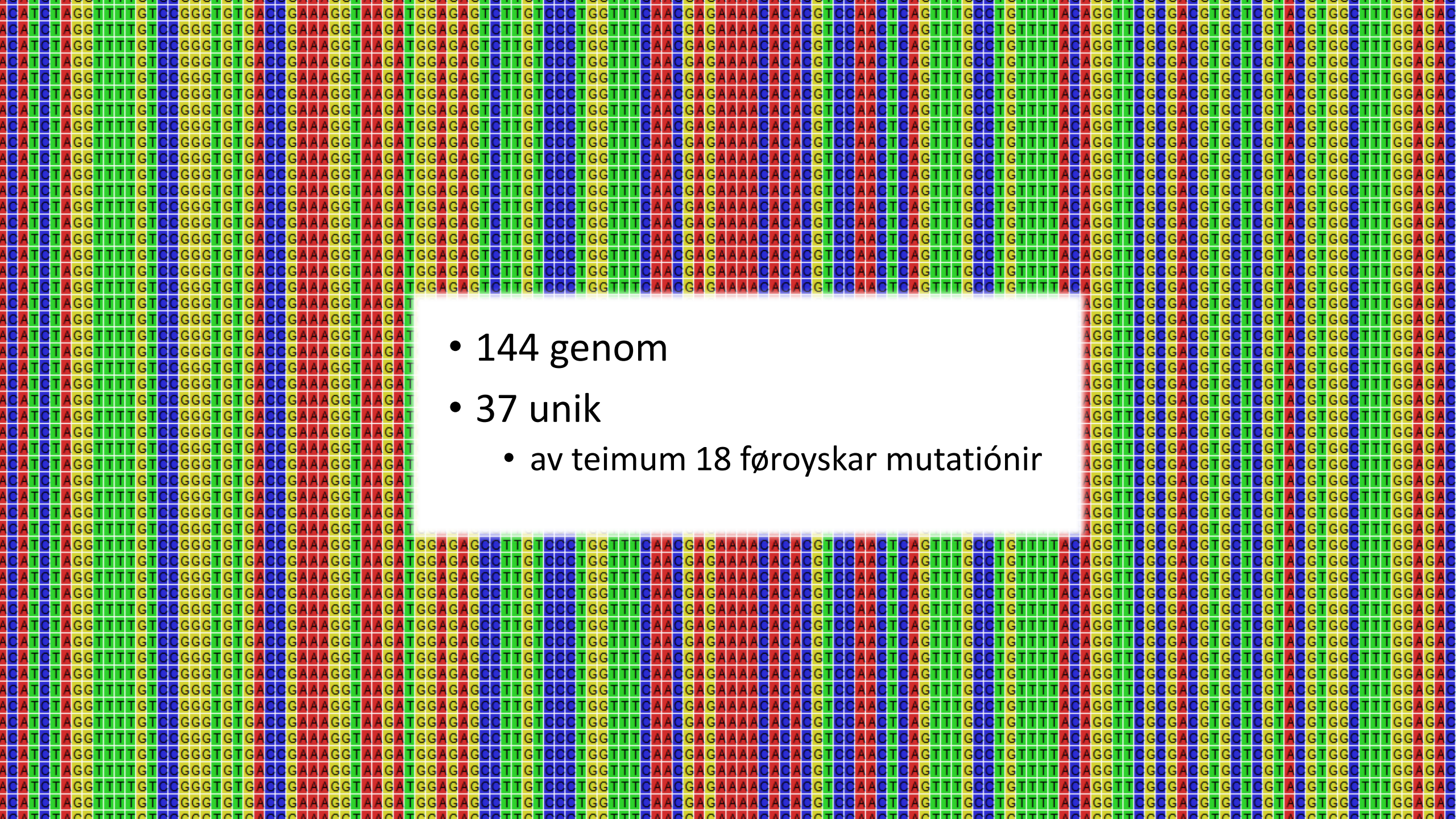

- 144 genom
- 37 unik
  - av teimum 18 føroyskar mutatiórnir

# Mutatióðnir í Føroyum

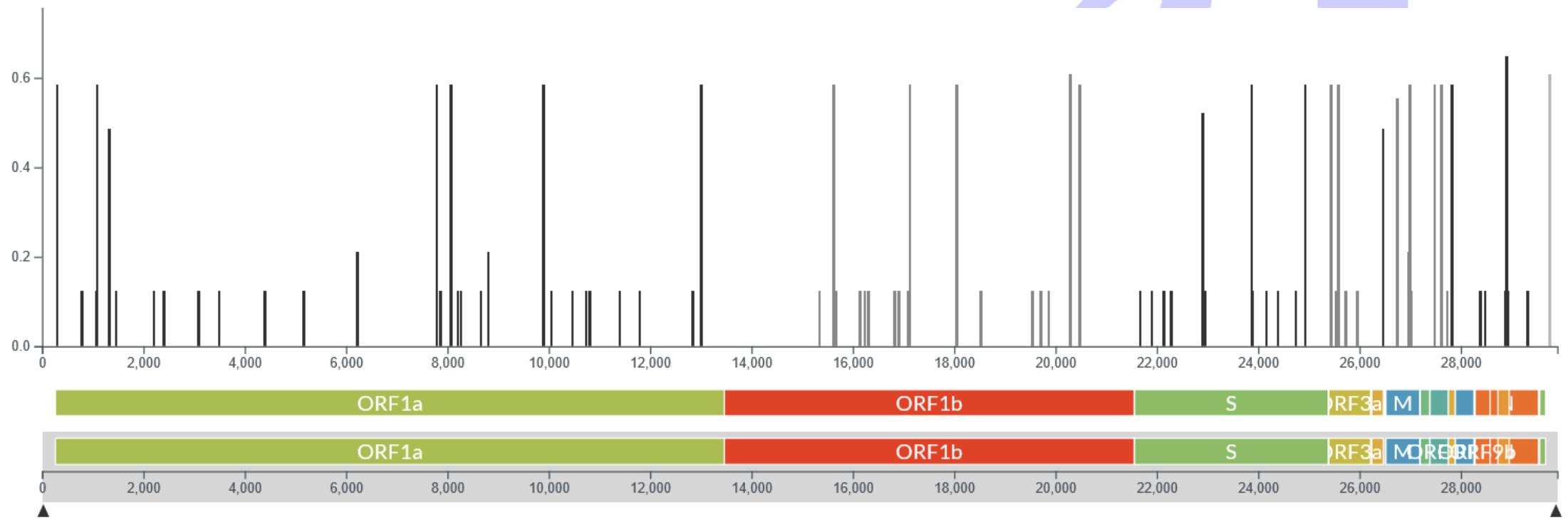

# Mutatióinir í verðini

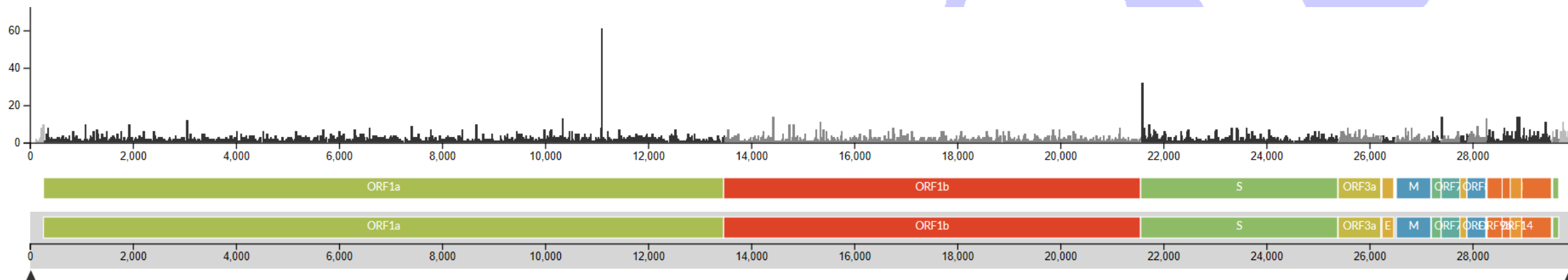

# GISAID Clades

RESET LAYOUT

Phylogeny  
GISAID Clade▲

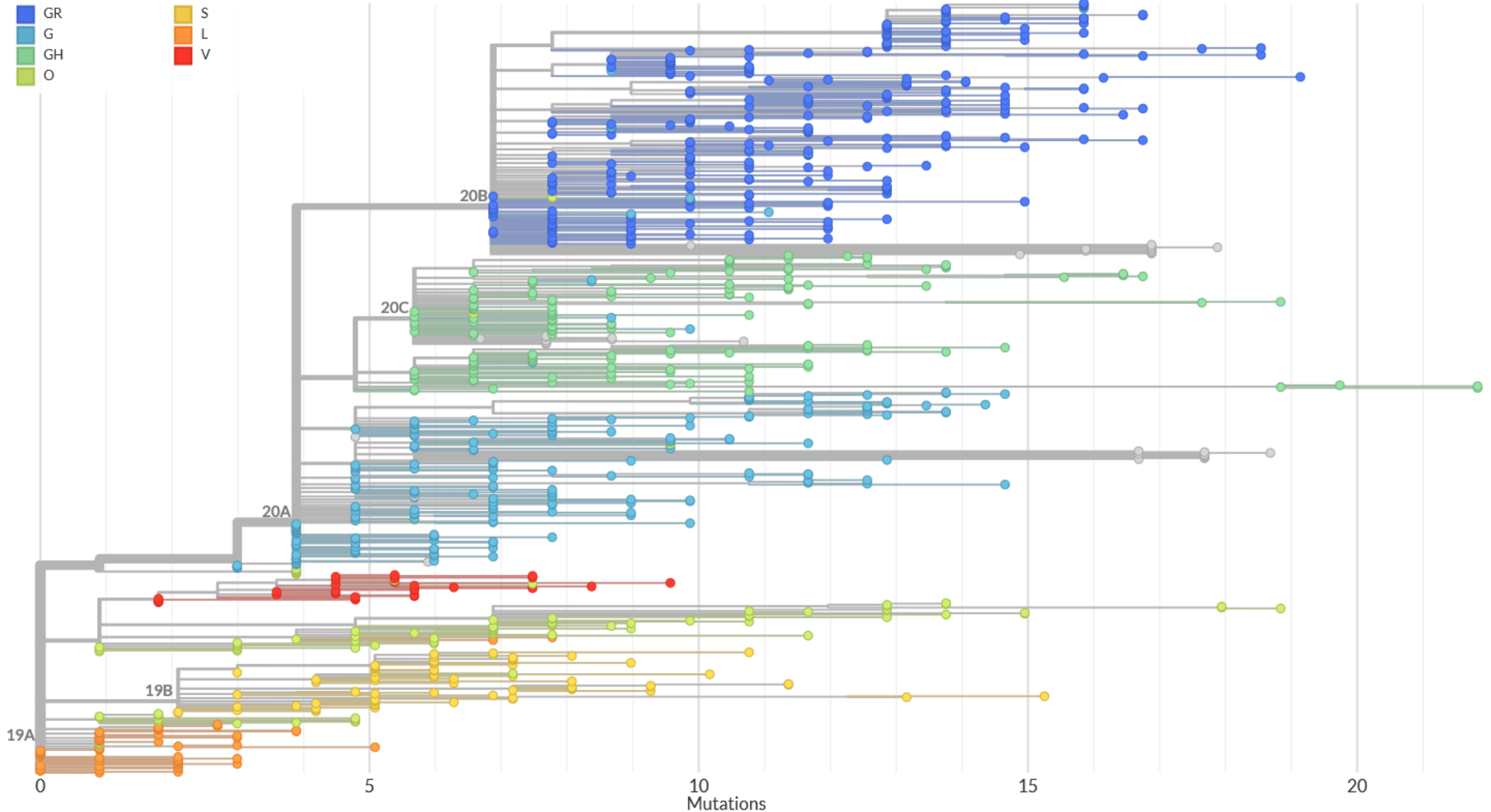

# Nextstrain Clades

Phylogeny  
Clade ^

- 19A
- 19B
- 20A
- 20B
- 20C

RESET LAYOUT

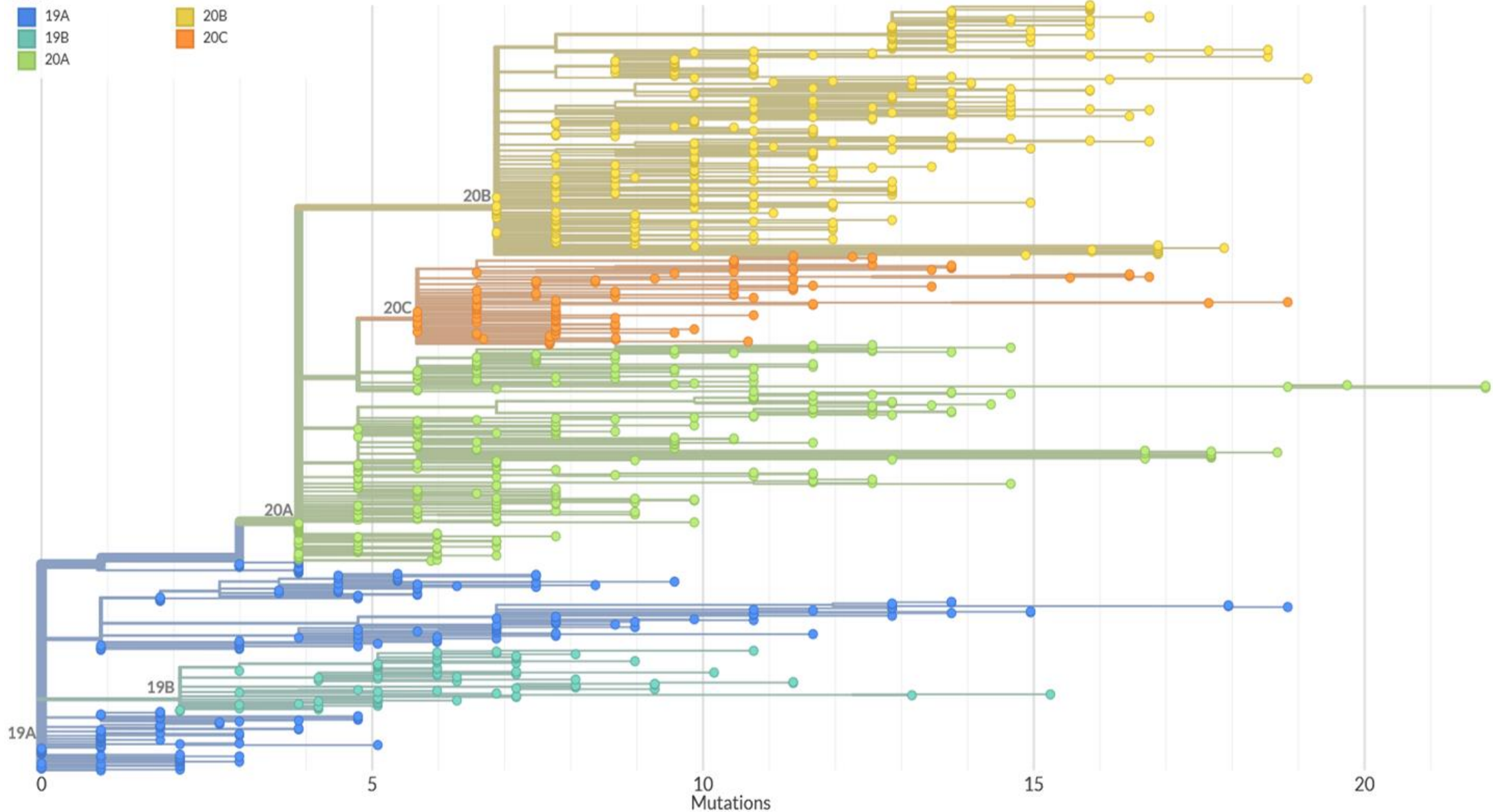

PLAY

RESET

Clade

- 19A
- 19B
- 20A
- 20B
- 20C



2019



PLAY RESET

Clade ^

- 19A
- 19B
- 20A
- 20B
- 20C

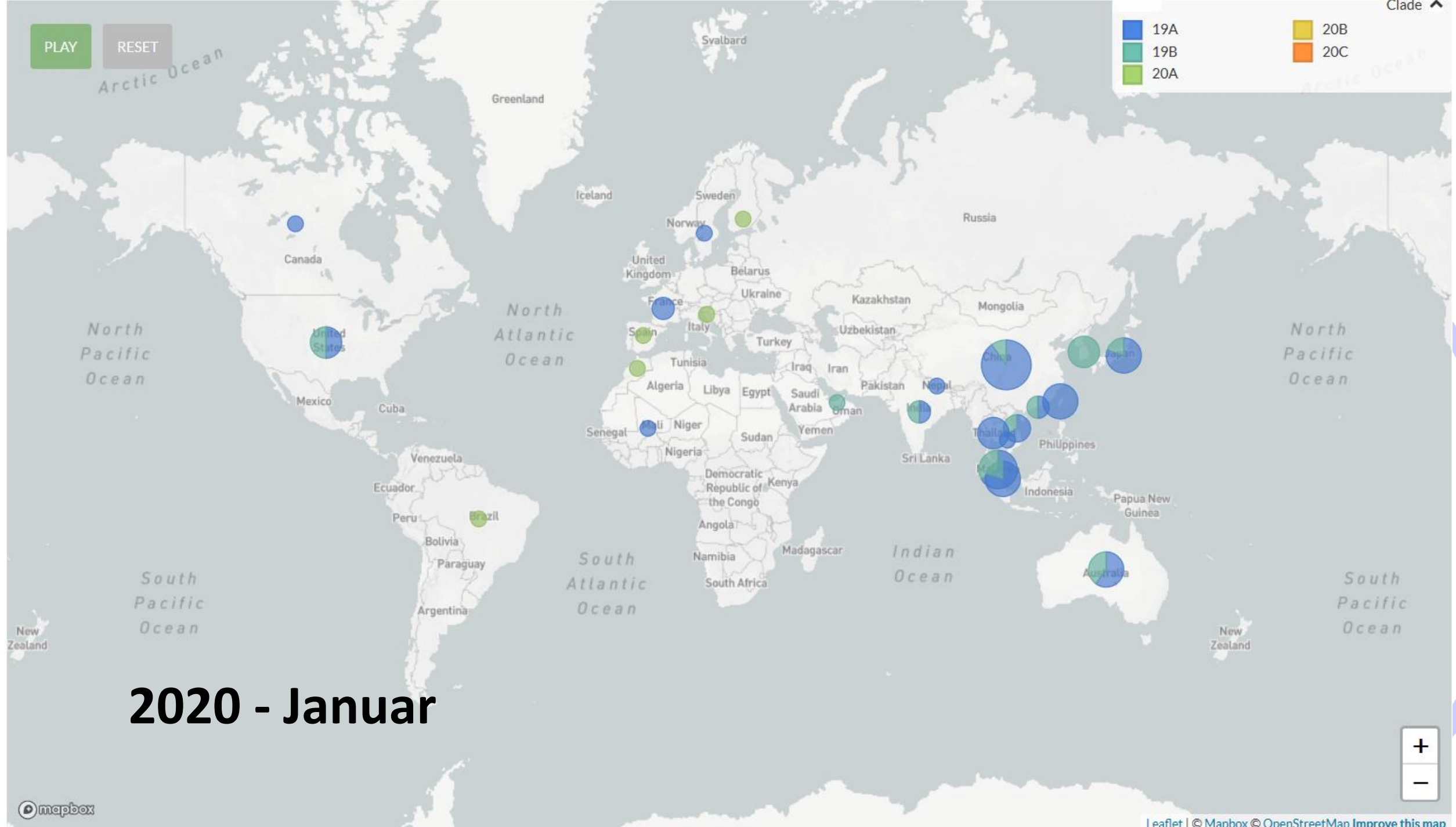

2020 - Januar

+  
-

PLAY RESET

Clade

- 19A
- 19B
- 20A
- 20B
- 20C

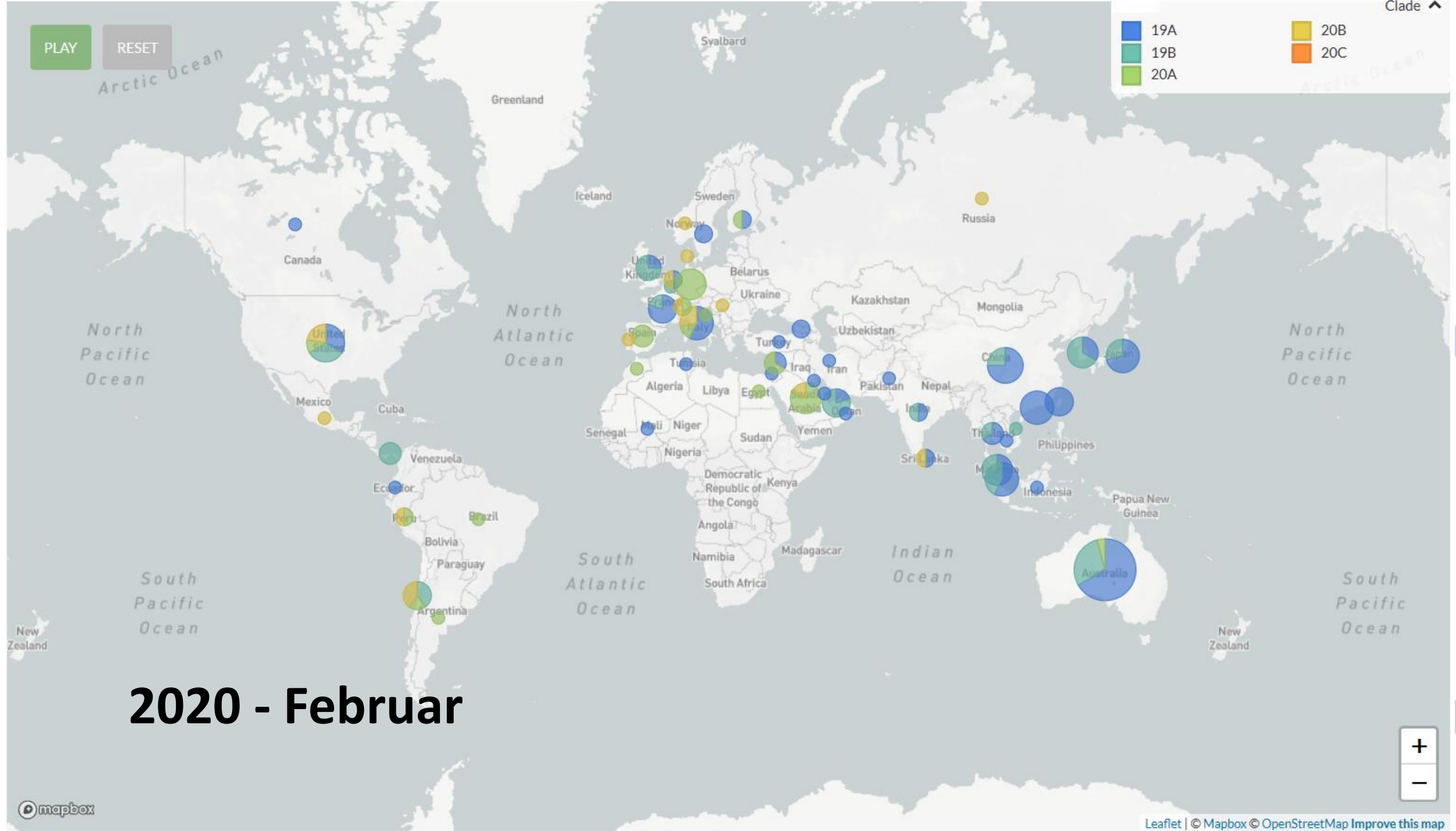

# 2020 - Februar

+  
-



PLAY

RESET

Clade

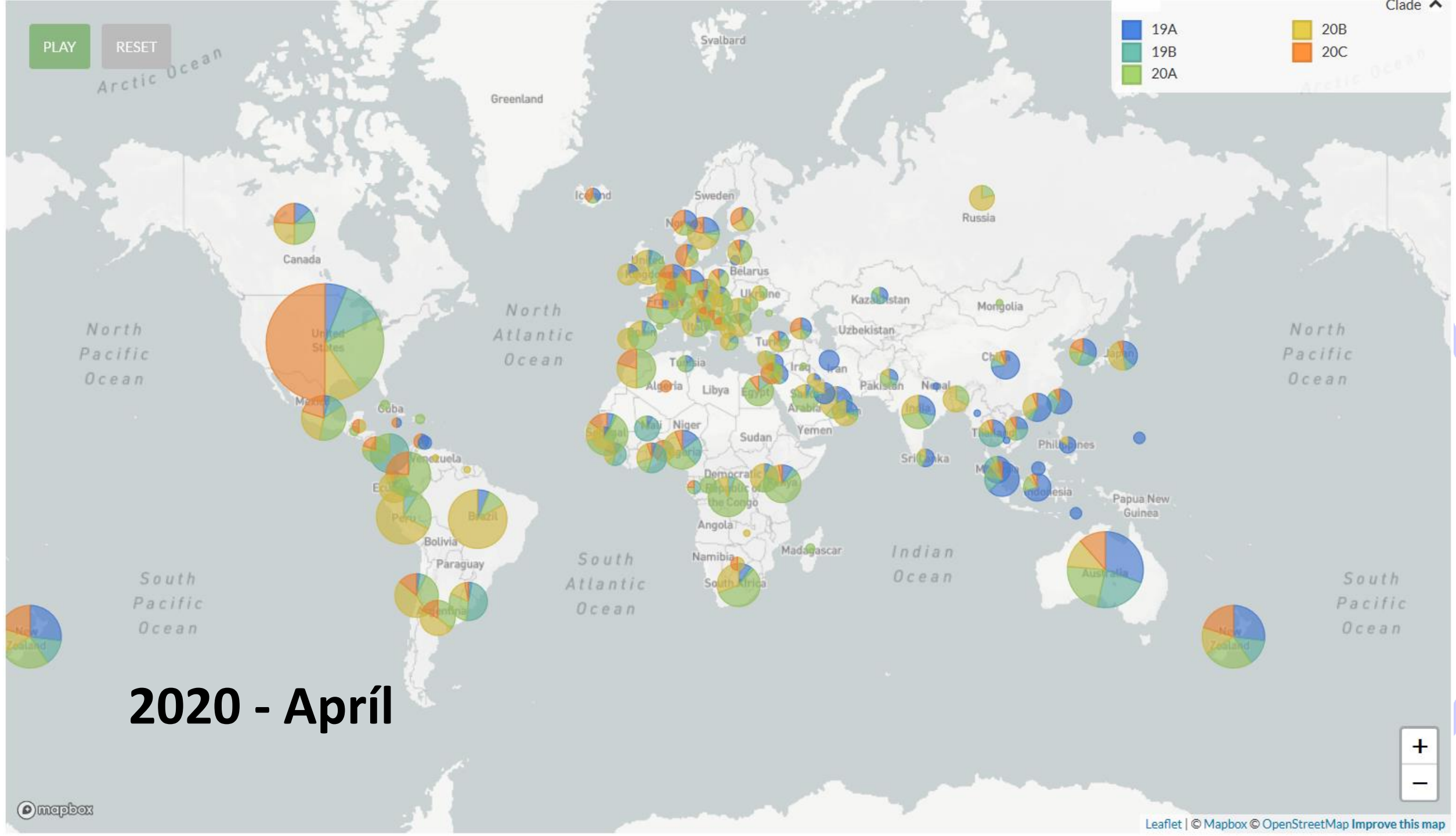
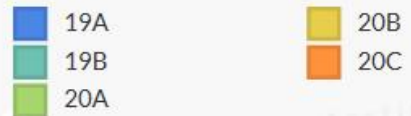

2020 - April

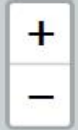

PLAY

RESET

Clade



Frequencies (colored by Clade)

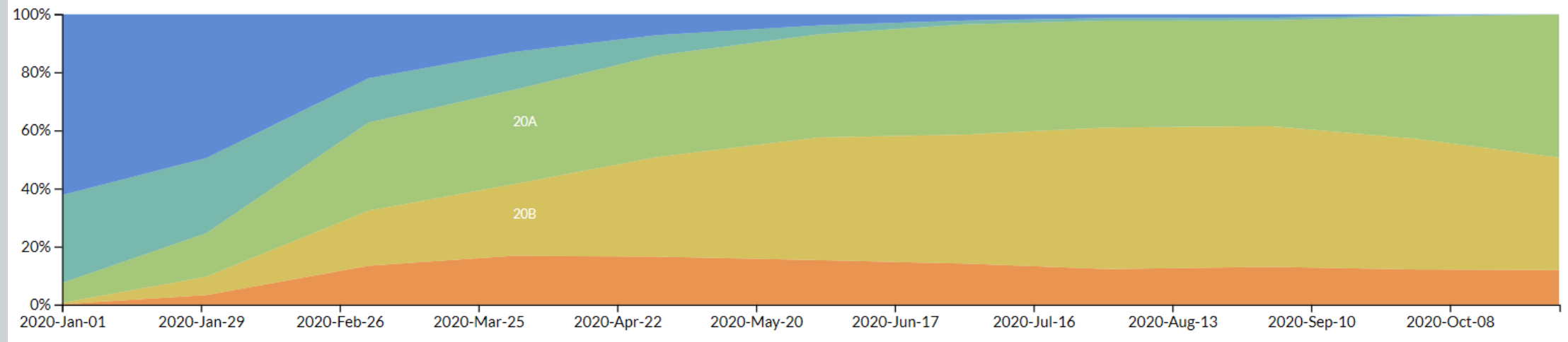

PLAY

RESET

Clade

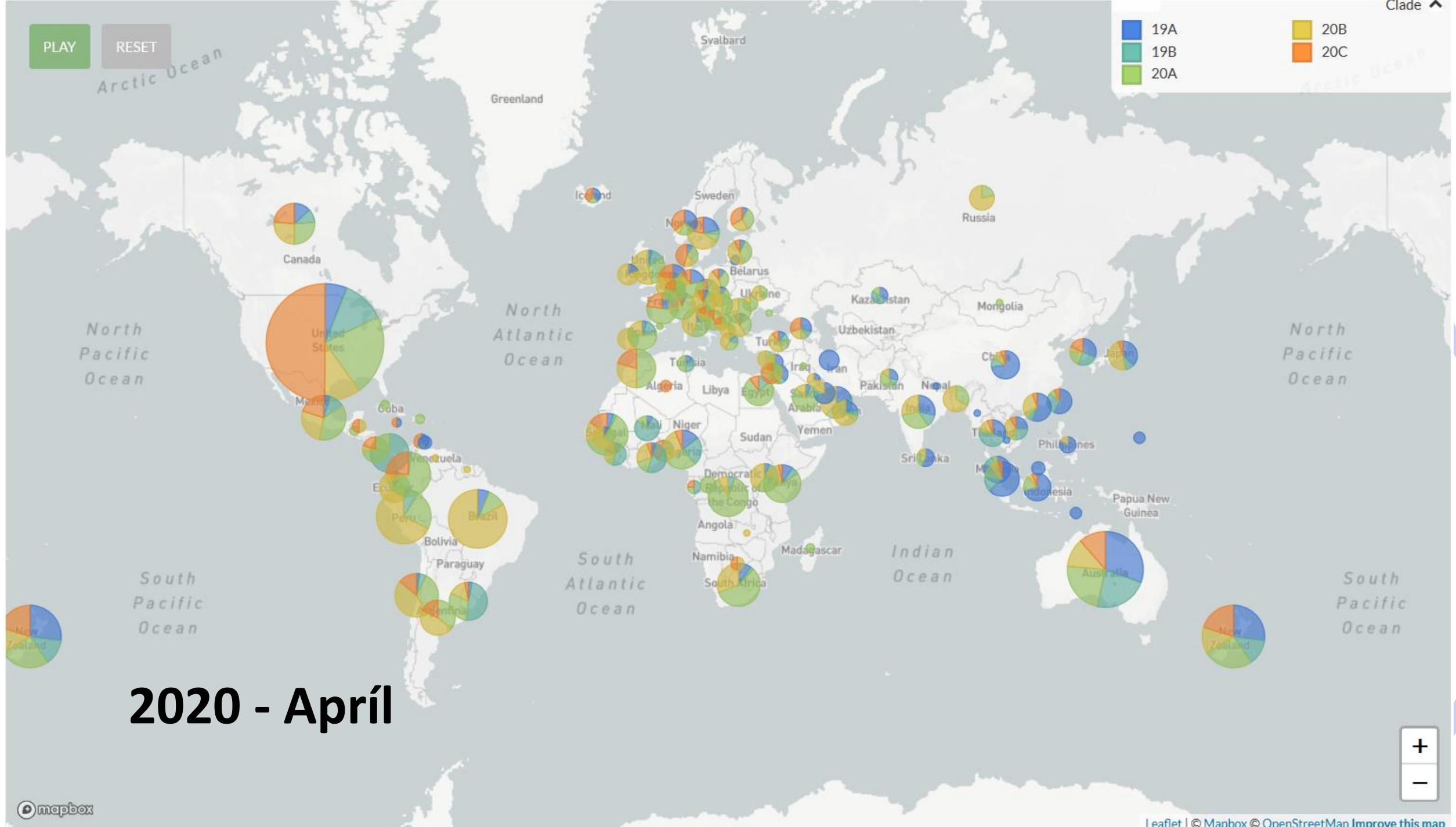
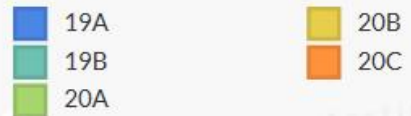

2020 - April



PLAY RESET

Clade ^

- 19A
- 19B
- 20A
- 20B
- 20C

Gannet  
ontrose  
Marine  
ed Area

North  
Sea

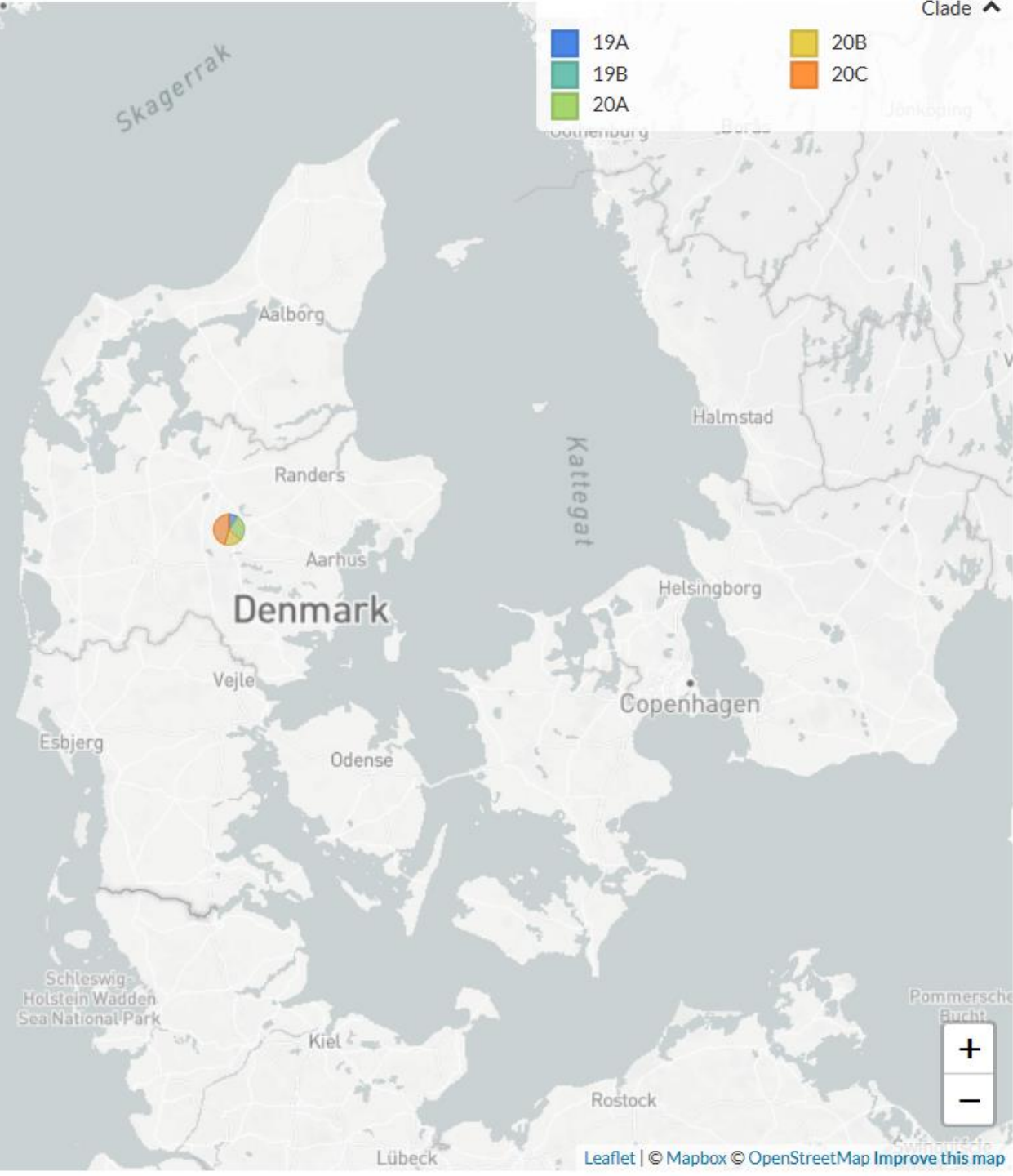

# 2020 - April

PLAY

RESET

PLAY

RESET

Gannet  
ontrose  
Marine  
ed Area

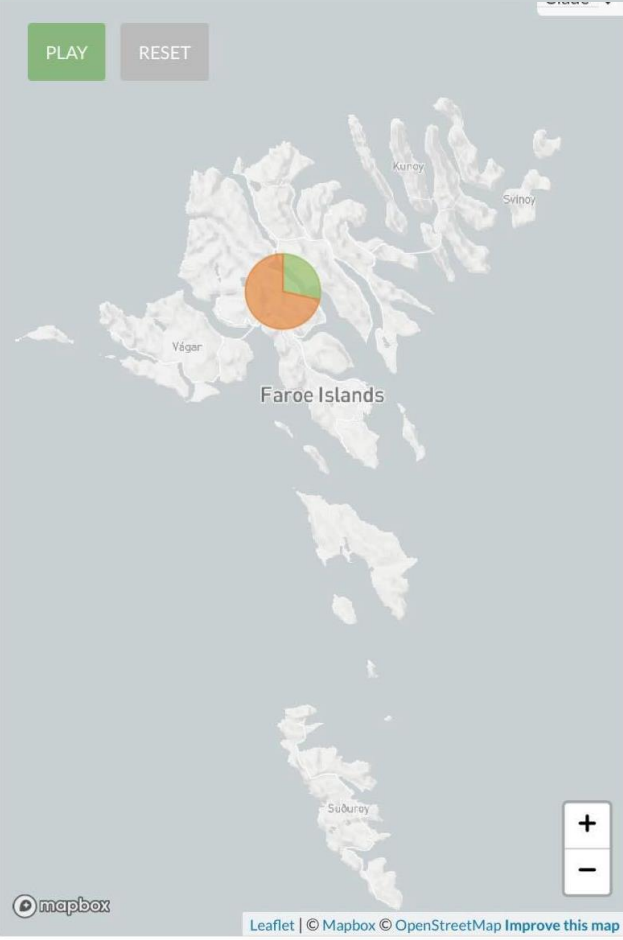

mapbox

Leaflet | © Mapbox © OpenStreetMap Improve this map



# 2020 - Apríl

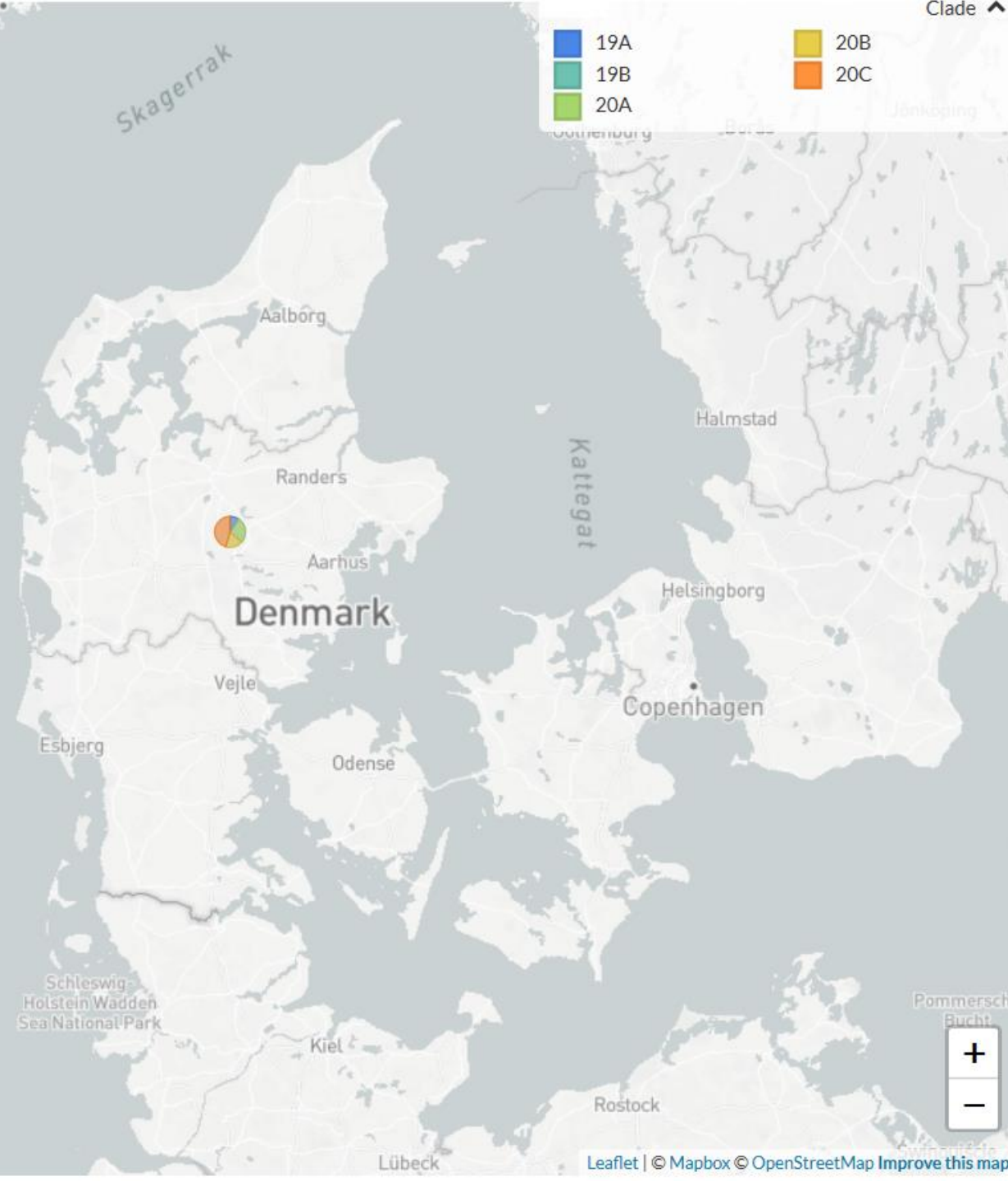

+  
-

Leaflet | © Mapbox © OpenStreetMap Improve this map

mapbox

# Smittan í Føroyum

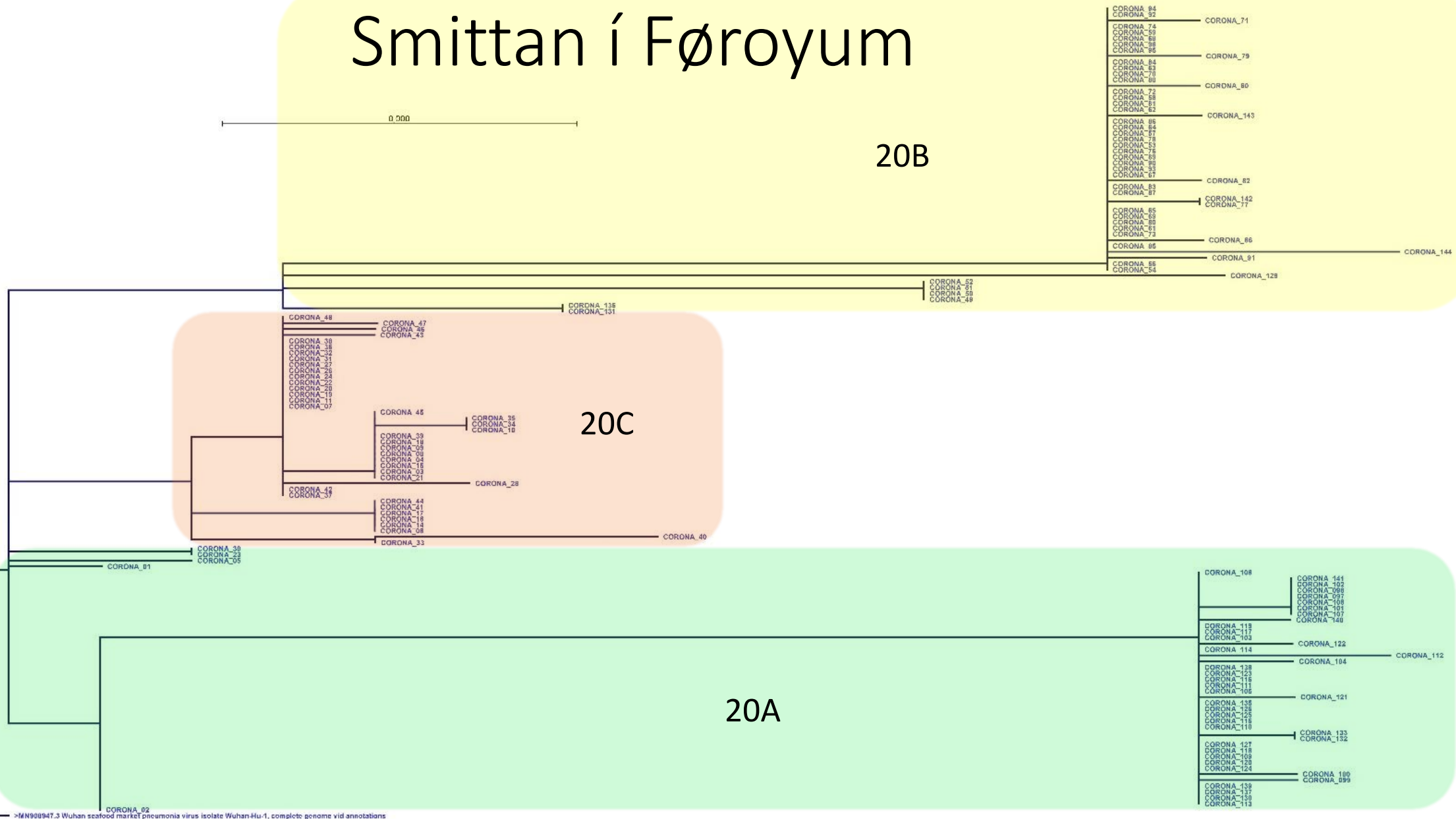

# Útbrot 1

0.000

20B

CORONA\_84  
CORONA\_82  
CORONA\_74  
CORONA\_59  
CORONA\_88  
CORONA\_38  
CORONA\_86  
CORONA\_71  
CORONA\_79  
CORONA\_84  
CORONA\_83  
CORONA\_70  
CORONA\_80  
CORONA\_72  
CORONA\_58  
CORONA\_81  
CORONA\_82  
CORONA\_80  
CORONA\_84  
CORONA\_57  
CORONA\_78  
CORONA\_53  
CORONA\_76  
CORONA\_59  
CORONA\_90  
CORONA\_33  
CORONA\_57  
CORONA\_83  
CORONA\_87  
CORONA\_82  
CORONA\_142  
CORONA\_77  
CORONA\_85  
CORONA\_59  
CORONA\_80  
CORONA\_81  
CORONA\_73  
CORONA\_86  
CORONA\_86  
CORONA\_81  
CORONA\_86  
CORONA\_85  
CORONA\_54  
CORONA\_128  
CORONA\_144  
CORONA\_91

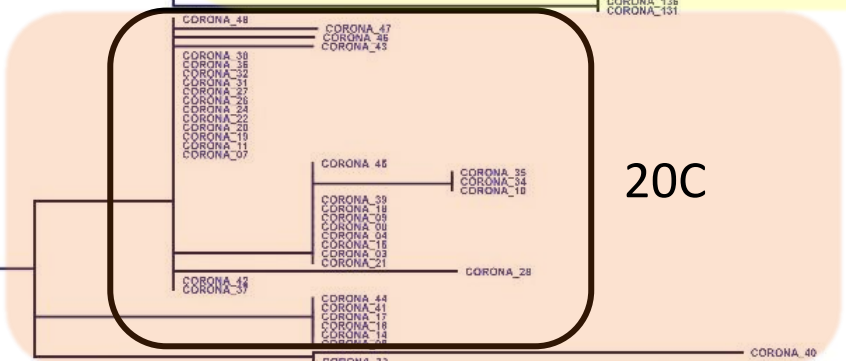

20C

03.-16. Mars

20A

CORONA\_108  
CORONA\_144  
CORONA\_102  
CORONA\_088  
CORONA\_098  
CORONA\_097  
CORONA\_108  
CORONA\_101  
CORONA\_107  
CORONA\_140  
CORONA\_119  
CORONA\_117  
CORONA\_103  
CORONA\_114  
CORONA\_122  
CORONA\_104  
CORONA\_128  
CORONA\_123  
CORONA\_116  
CORONA\_111  
CORONA\_106  
CORONA\_121  
CORONA\_126  
CORONA\_125  
CORONA\_119  
CORONA\_110  
CORONA\_133  
CORONA\_132  
CORONA\_127  
CORONA\_118  
CORONA\_109  
CORONA\_120  
CORONA\_124  
CORONA\_100  
CORONA\_099  
CORONA\_139  
CORONA\_137  
CORONA\_150  
CORONA\_113

# Útbrot 2

0.000

20B

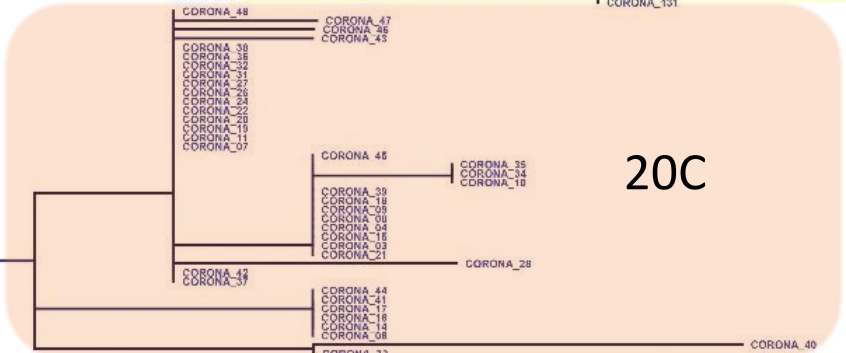
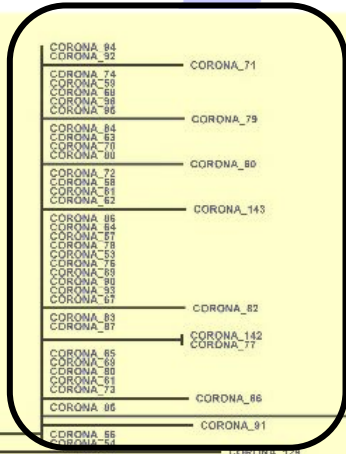

04.-12. August

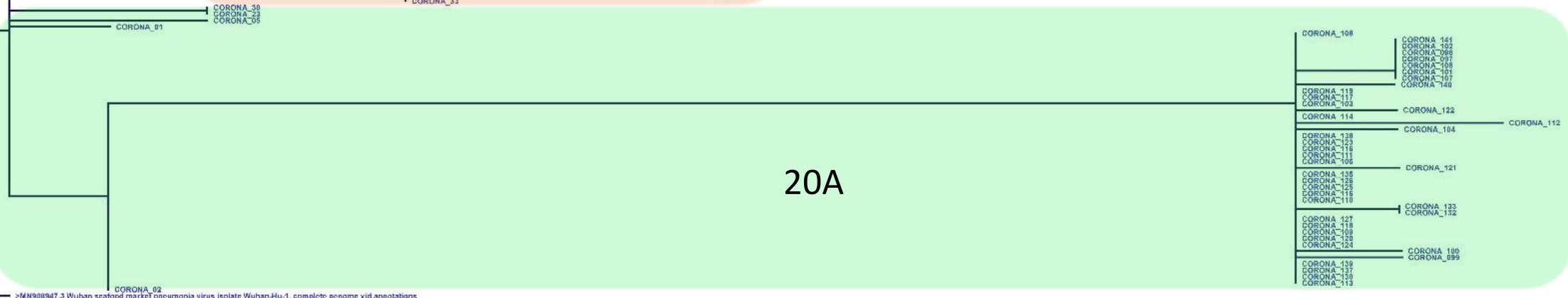

->MN900947.3 Wuhan seafood market pneumonia virus isolate Wuhan-Hu-1, complete genome vif annotations



# Útbrot 3

0,000

20B

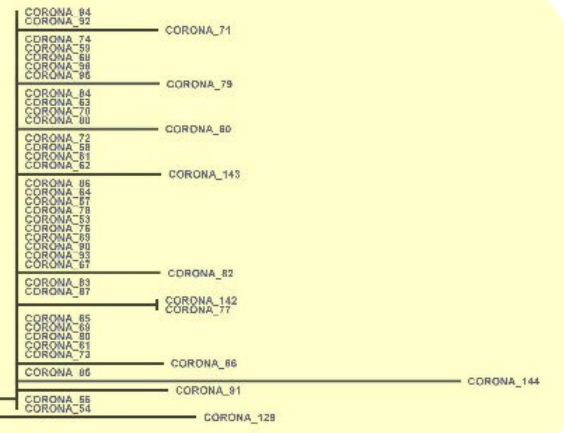

20C

18.-30. Septembur

20A

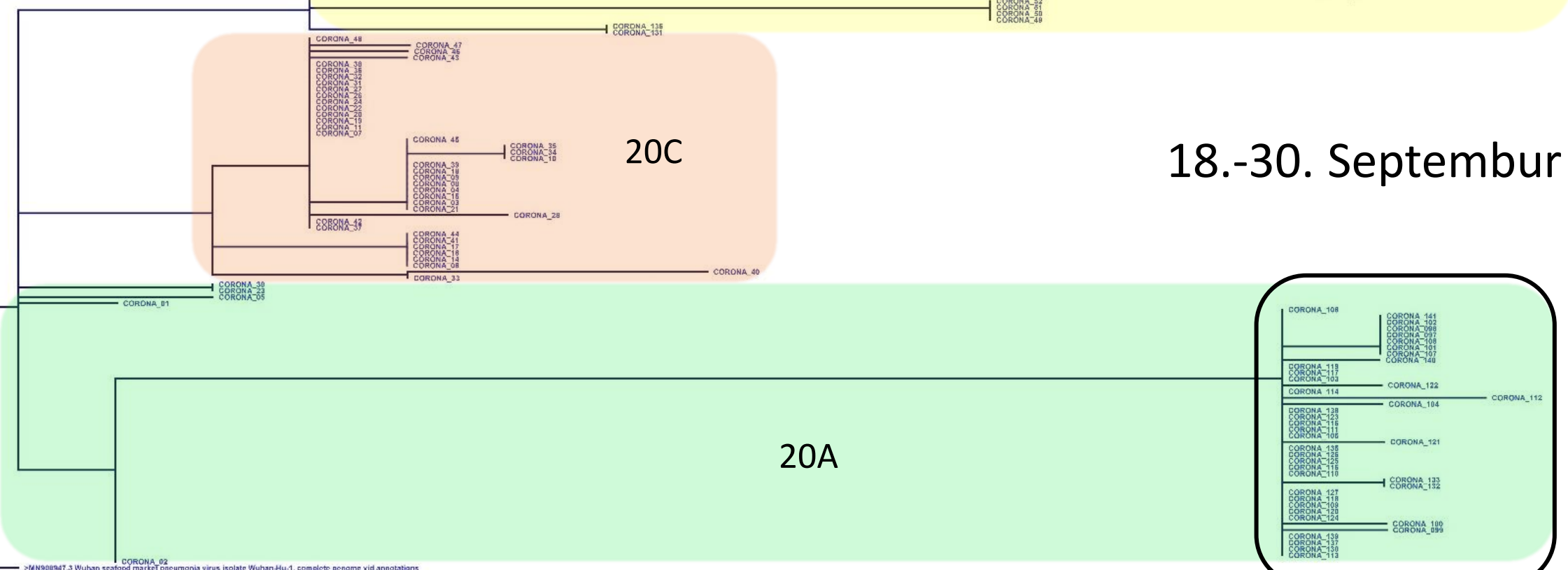

→ MN908947.3 Wuhan seafood market pneumonia virus isolate Wuhan-Hu-1, complete genome vif annotations



# Víðari gransking

- Samanlíkna sekventeringsúrslit við væntaðar smittuketur
- Genomsekventera allar enn ókendar smittuketur
- Menna eina skjótari metodu at genomesekventera virusgenom
  - MinION





Vísinda) *vøka*